

Outer Panel Dihedral = 1°

Anti-Spin Parachute

The Fans are pumps to create compressed air to drive the wing Correctors

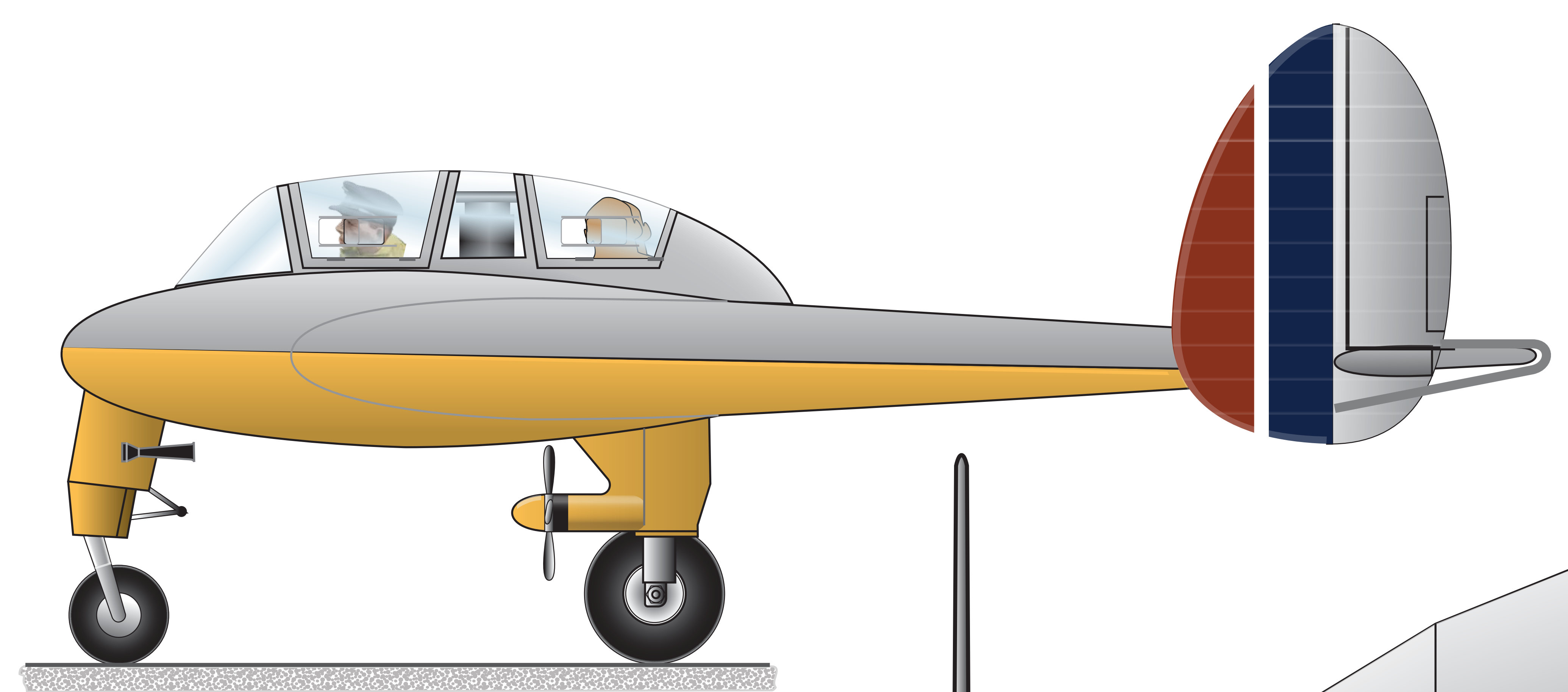

Span	53 ft 10 in	16.41 m
Length	19 ft 4 in	5.89 m
Height	8 ft 4 in	2.54 m
Wing Area	443.04 ft <sup>2</sup>	41.16 m <sup>2</sup>
Load weight	6000 lbs	2720 kg
Empty weight	4450 lbs	2017 kg

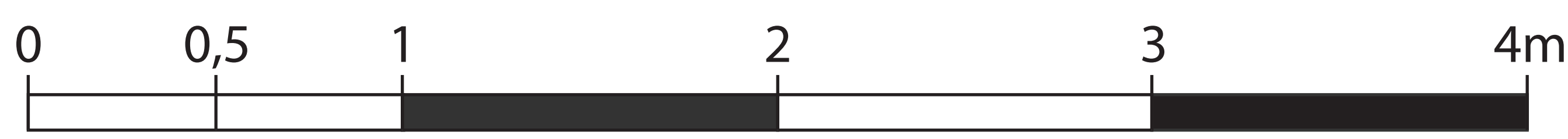


Drawn by: Vincent Cockett - 2012 ©

**A.W. 52 Glider built by ARMSTRONG WHITHWORTH AIRCRAFT LTD - 1945**